



REPLAY CAMERAS

APPLICATIONS

Volumetric Video Capture

4D Facial Scanning

Motion Capture & Analysis

4D Full Body Scanning



FEATURES INCLUDE:

- High Quality CMOS Image Sensors
- Internal Recording Direct to Solid State Media
- 10 Gigabit Ethernet for Control, Video Streaming and High Speed File Download
- 12G-SDI Ultra-HD Live Monitoring Output
- C-Mount or Optional Active EF-Mount
- Compact One-Piece Rugged Design
- Easily Synchronize Multiple Cameras

SPECIFICATIONS

CMOS Image Sensor	Various Sony and Gpixel sensor options. See chart below. Most models available in color or monochrome (C/M).
Internal Recording	Uncompressed or lossless-compressed RAW recording to internal SSD (up to 1920GB capacity).
10 Gigabit Ethernet	Fast network interface for camera configuration, recording control, live and playback video streaming, and high-speed file transfer. SFP+ port allows various connectivity options including optical fiber or copper cabling.
PTP Synchronization	IEEE1588 Precision Time Protocol can be used for frame timestamping and exposure synchronization.
SMPTE LTC Input	LTC reference can be used for frame timestamping and exposure synchronization.
SDI Video Output	Live video monitoring via single-link 12G/6G/3G, supports 1080p or UHD up to 60fps.
Tri Level Sync Input	SMPTE HD sync reference can be used for exposure synchronization.
Additional I/O	TTL input/output for exposure synchronization, strobe light synchronization, status signals, etc.
Control Interface	IO Industries StudioCap-VC software or custom-developed application using Volucam SDK.

Mechanical/Electrical

Dimensions / Weight	60.2 mm (W) x 62.0 mm (H) x 130.4 mm (D), 670g (without lens).
Lens Mount	C-mount or optional Active EF-mount (VICLENSMOUNT-A).
Power Requirements	12V DC, approx. 14W. Universal AC Adapter available (VICPWR) or AC Adapter w. TTL break-out (VICPWRI0).
Operating Temperature	0°C to 30°C, 20-85% humidity (non-condensing).

MODEL OVERVIEW

Model	CMOS Image Sensor	Max. Resolution	Optical Format	Shutter	FPS at Max. Resolution (8/10/12-bit)
24A164[C/M]V	Sony Pregius IMX174	1920 x 1216	1/1.2" (13.3mm)	Global	164 / 164 / 128
32B216[C/M]V	Sony Pregius IMX252	2048 x 1544	1/1.8" (8.9mm)	Global	216 / 191 / 118
32B55CV	Sony Pregius IMX265	2048 x 1544	1/1.8" (8.9mm)	Global	55 / 55 / 55
51B163[C/M]V	Sony Pregius IMX250	2432 x 2056	2/3" (11.0mm)	Global	163 / 144 / 89
89B93[C/M]V	Sony Pregius IMX255	4096 x 2176	1" (16.0mm)	Global	93 / 88 / 63
89B64CV	Sony Pregius IMX305	4096 x 2176	1" (16.0mm)	Global	63 / 63 / 63
90G120[C/M]V	Gpixel GMAX2509	4224 x 2160	2/3" (11.9mm)	Global	120 / 100 / 85
120B68[C/M]V	Sony Pregius IMX253	4096 x 3008	1.1" (17.5mm)	Global	68 / 64 / 46
202D73[C/M]V	Sony Pregius IMX531	4480 x 4512	1.1" (17.4mm)	Global	73 / 59 / 49
245D60[C/M]V	Sony Pregius IMX530	5312 x 4608	1.2" (19.3mm)	Global	60 / 48 / 40 (60*)
262G41[C/M]V	Gpixel GMAX0505	5120 x 5120	1.1" (18.1mm)	Global	41 / 36 / 30

*with lossless recording

SAMPLE CONFIGURATION

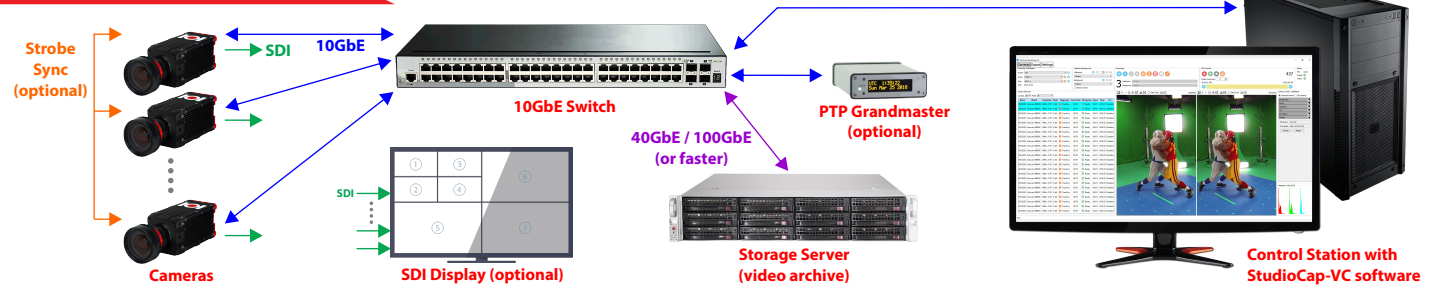

MECHANICAL DIAGRAMS

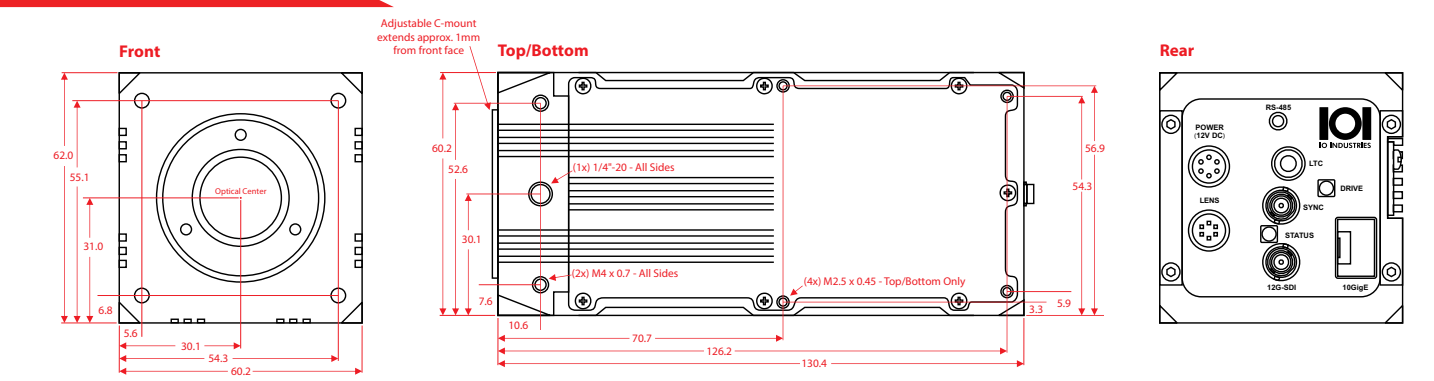

Visit us at: www.ioindustries.com
 15940 Robin's Hill Road
 London, Ontario, Canada, N5V 0A4
 Tel: +1 519 663 9570
 Email: sales@ioindustries.com

LET'S STAY CONNECTED!



@IOINDUSTRIES



@IOINDUSTRIES



@IO-INDUSTRIES

Copyright © 2022 IO Industries Inc. Volucam is a trademark of IO Industries.
 All other trademarks are the property of their respective owners.

Datasheet Rev. 1.8 (04/06/2022)
 Specifications subject to change without notice